

Part Number:

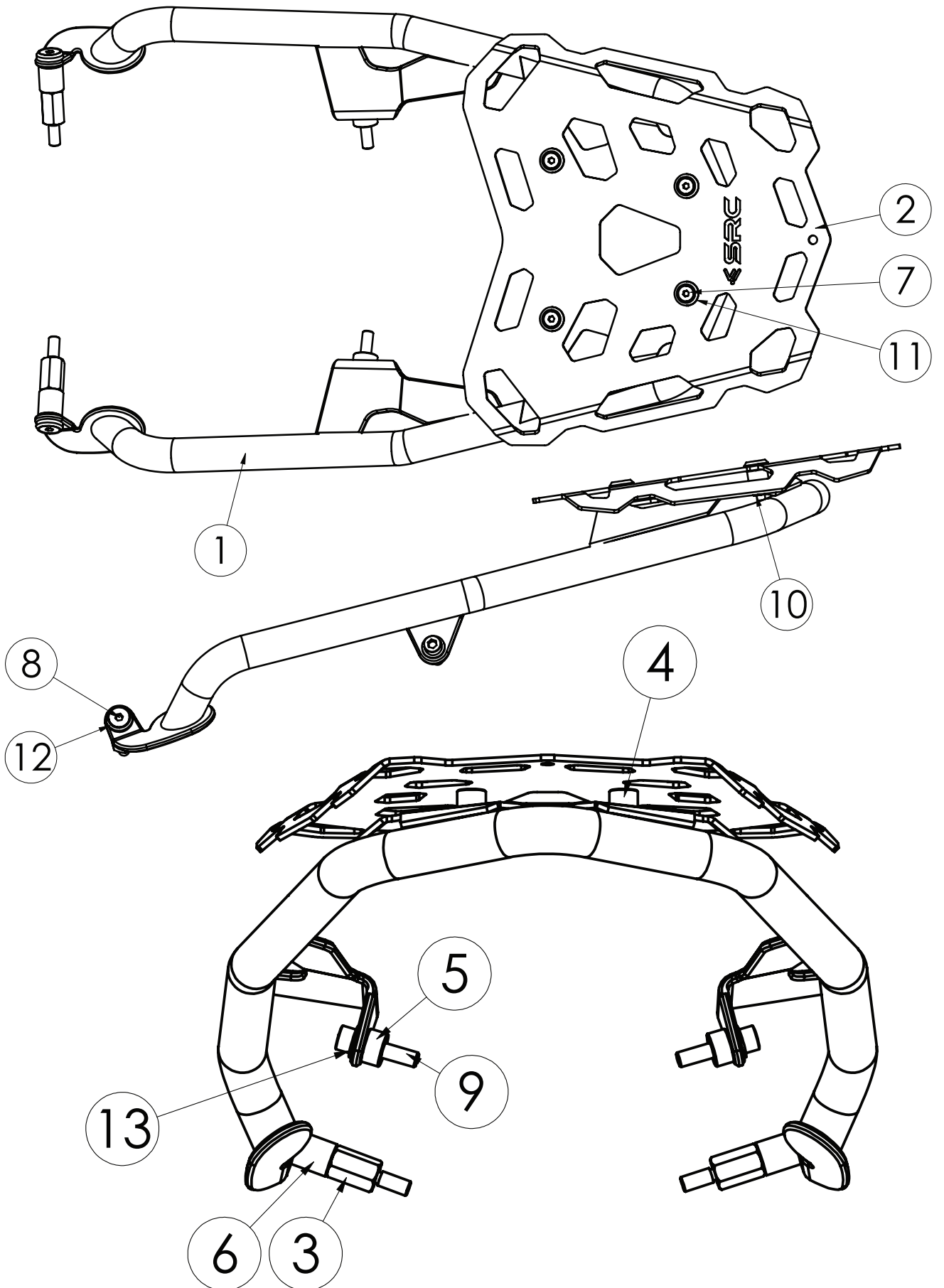









Part Description: TOP RACK YAMAHA TENERE 700 2025

Installation / Parts List / Bill of Material for Mounting

NO.	Description	Quantity	Torque*(N-M)	Remarks**
1	rack t7 2025	1		
2	top plate	1		
3	hxagonal shaft 16x25	2		
4	bush al od15xid7xh10	4		
5	bush al od18xid9xl10	2		
6	bush al od18xid9xl20	2		
7	socket countersunk head screw m6x30	4		Use Liquid Thread Locker
8	socket countersunk head screw m8x45	2		Use Liquid Thread Locker
9	socket head cap screw m8x35	2		Use Liquid Thread Locker
10	hex flange nut gradea m6	4		
11	countersunk washer m6	4		
12	countersunk washer m8	2		
13	washer m8	2		
SRC Design uses Metric System of Measurement and all dimensions in Millimeters				
Recommended to use the Torque specified in the table				
Denotes Usage of Liquid Thread Locker in specified Locations				

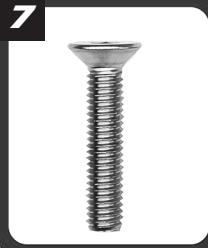
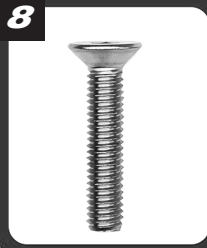
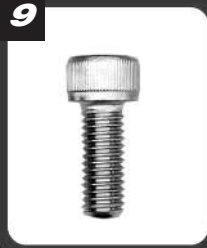

DESCRIPTION

 1	RACK T7 2025	 2	TOP PLATE	 3	HXAGONAL SHAFT 16X25
 4	BUSH AL OD15XID7XH10	 5	BUSH AL OD18XID9XL20	 6	BUSH AL OD18XID9XL10
 7	SOCKET COUNTERSUNK HEAD SCREW M6X30	 8	SOCKET COUNTERSUNK HEAD SCREW M8X45	 9	SOCKET HEAD CAP SCREW M8X35
 10	HEX FLANGE NUT GRADEA M6	 11	COUNTERSUNK WASHER M6	 12	COUNTERSUNK WASHER M8
 13	WASHER M8				

TOOLS REQUIRED



**Hex wrench
ITEM NO.
4 mm**



**Hex wrench
ITEM NO.
5 mm**



**socket wrench
torque
Torque**



**Thread
locked**

TORQUE VALUES TO BE USED IN MOUNTING INSTRUCTIONS

BOLT HEAD CODE	M4		M5		M6		M8		M10		M12		M14		M16		M18	
	CODE	Nm		Nm		Nm		Nm		Nm		Nm		Nm		Nm		Nm
INOX STAINLESS STEEL	A2	2.6		5.1		8.7		21.2		42		73		118		180		258
STEEL	8.8	3		5		10		23		46		79		127		198		283
STEEL	10.9	4		8.1		14		34		67		116		187		291		402

**Newton meter (symbol: N m or N·m) is the SI unit of torque.
One newton meter is defined as the torque resulting from a force of one newton applied perpendicularly to a moment arm of one meter in length.**

TORQUE VALUES TO BE USED IN MOUNTING INSTRUCTIONS



USE THE SPECIFIED TORQUE (NM) FOR SAFE AND PRECISE INSTALLATION.



THREADLOCKER PRIMARILY FUNCTIONS TO PREVENT THE LOOSENING OF BOLTS, SCREWS, OR OTHER THREADED FASTENERS.

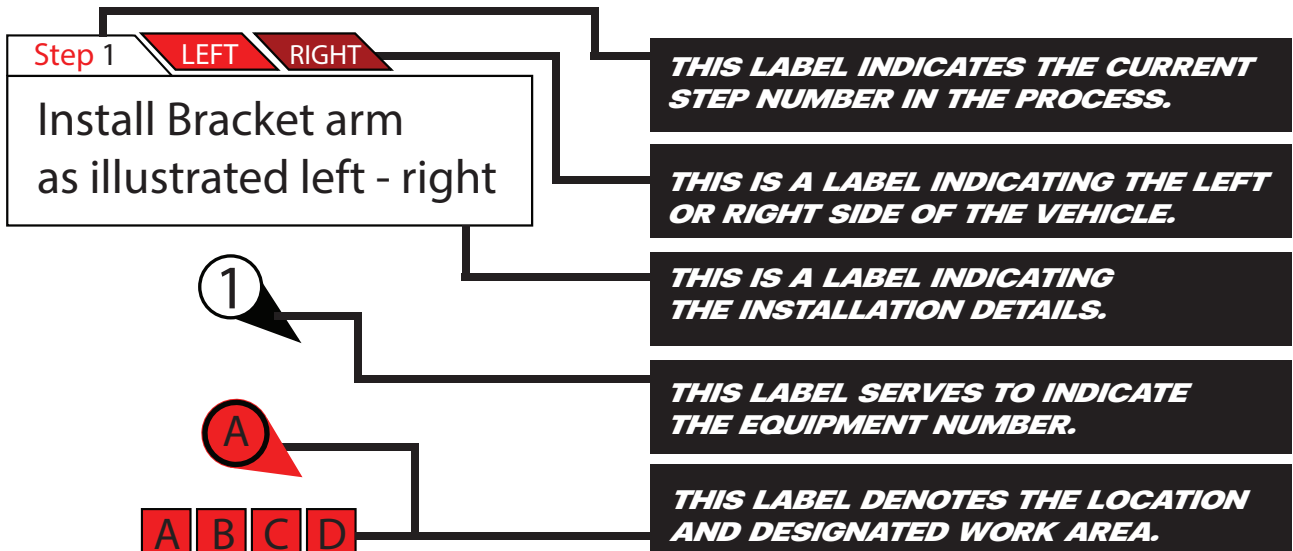

RIGHT (R)

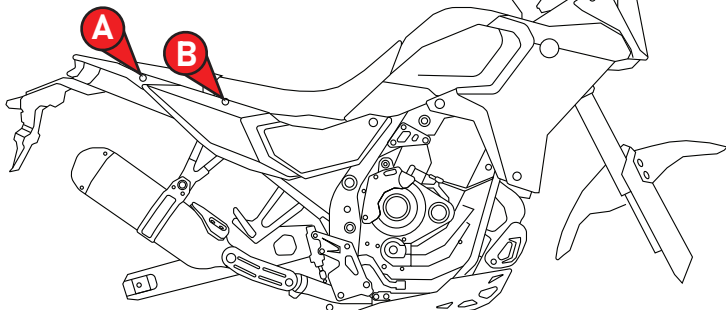

LEFT (L)

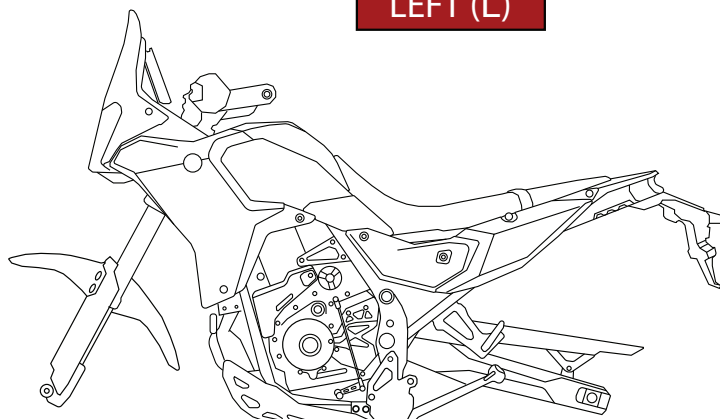

Step 1 **RIGHT**

Remove the original bushing bolt as shown in the illustration.

A B **RIGHT**

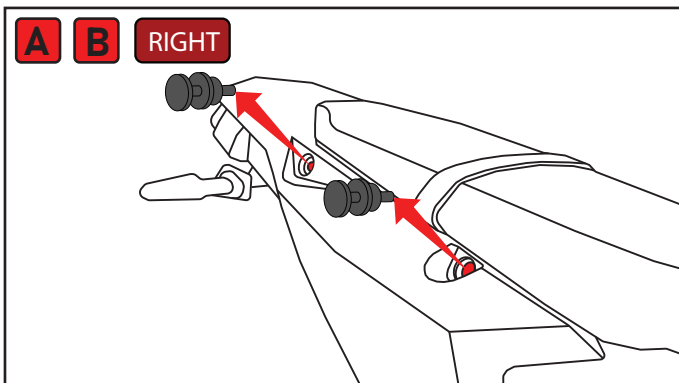

A B **LEFT**

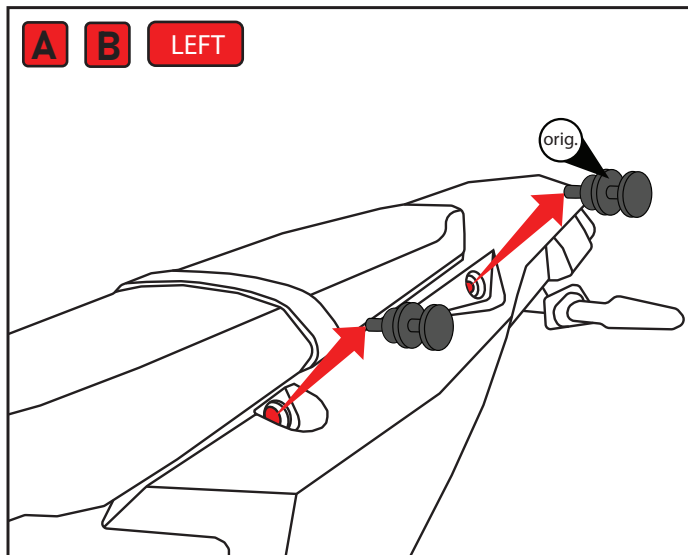

Step 2 **RIGHT**

Assemble the parts according to the numbered diagram as shown.

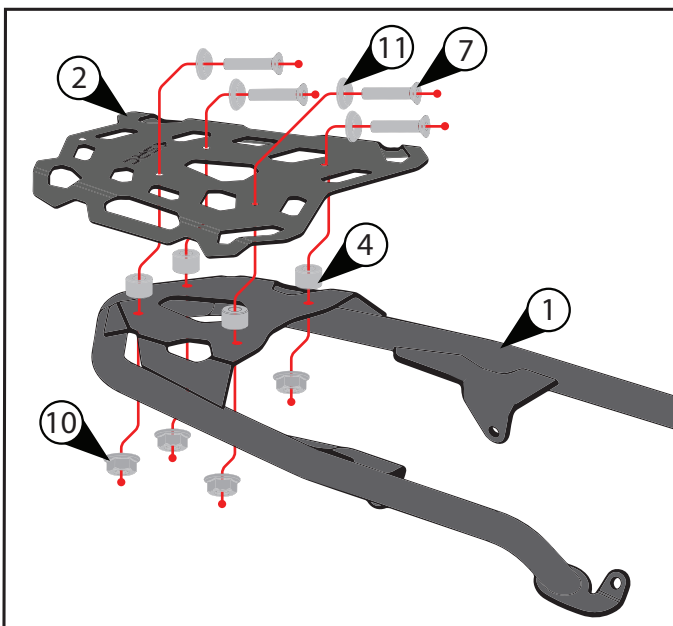

Step 3

RIGHT LEFT

Install parts No.3 and No.10 on both the left and right sides as shown.

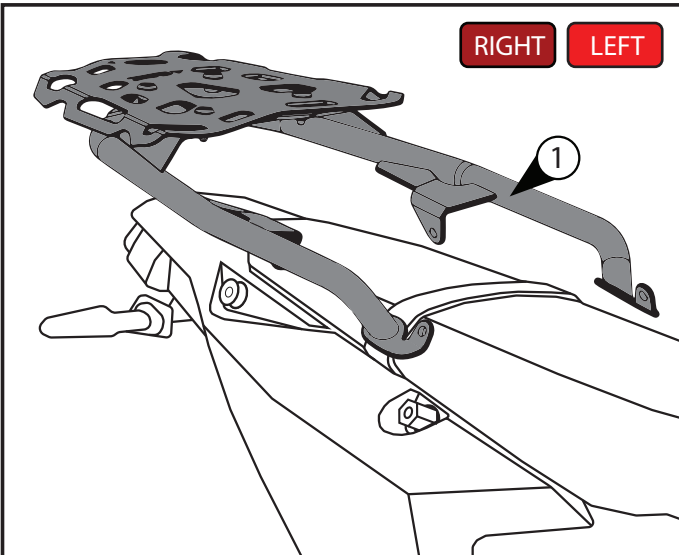
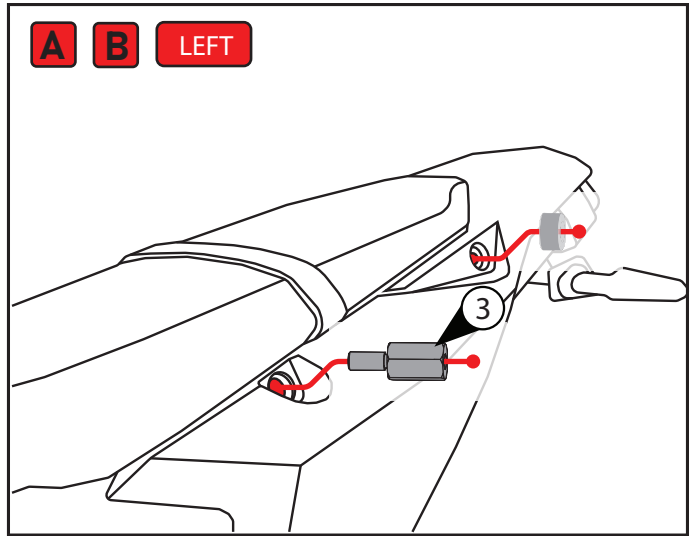
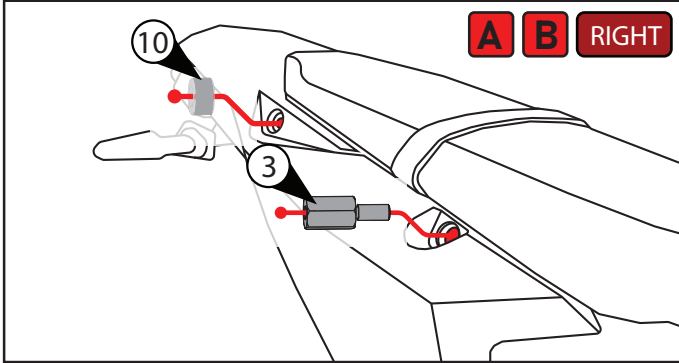

Step 4

RIGHT LEFT

Install parts No.1 as shown.

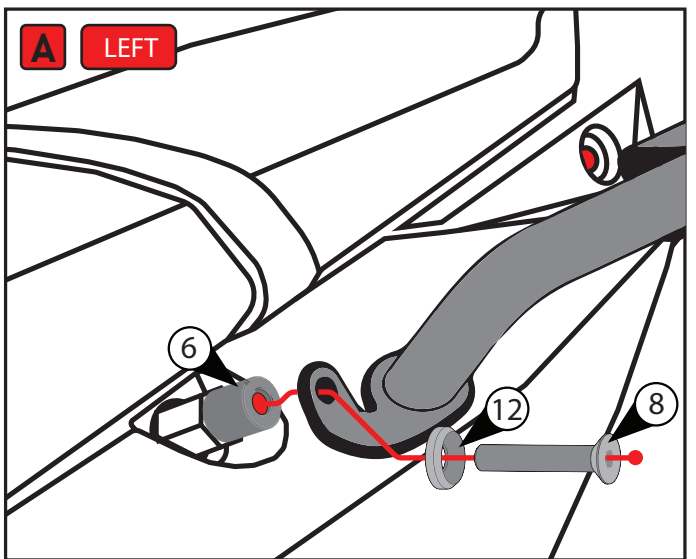
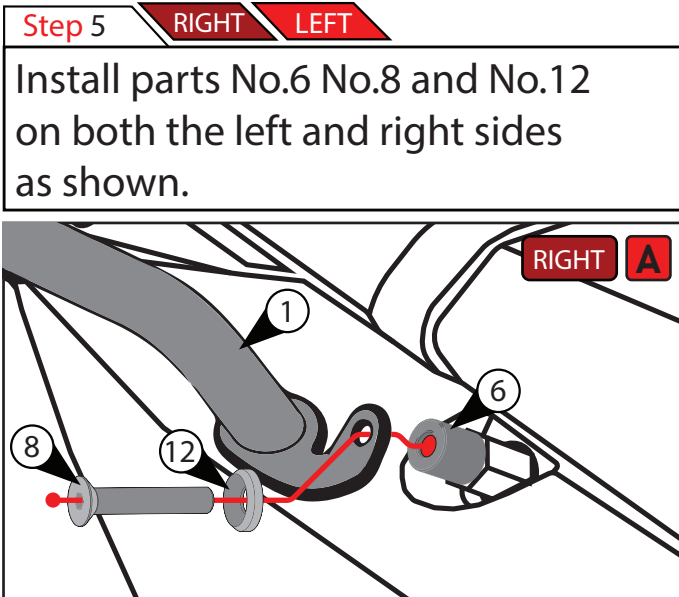

Step 5

RIGHT LEFT

Install parts No.6 No.8 and No.12 on both the left and right sides as shown.

Step 6

RIGHT

LEFT

Install parts No.3 and No.10 on both the left and right sides as shown.

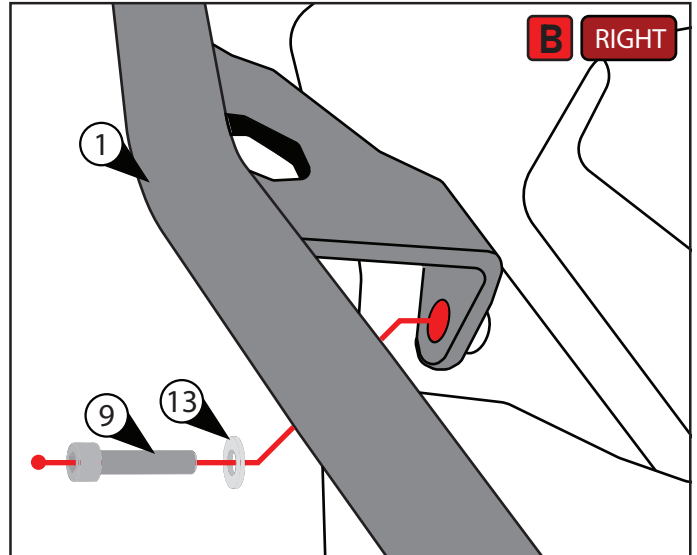
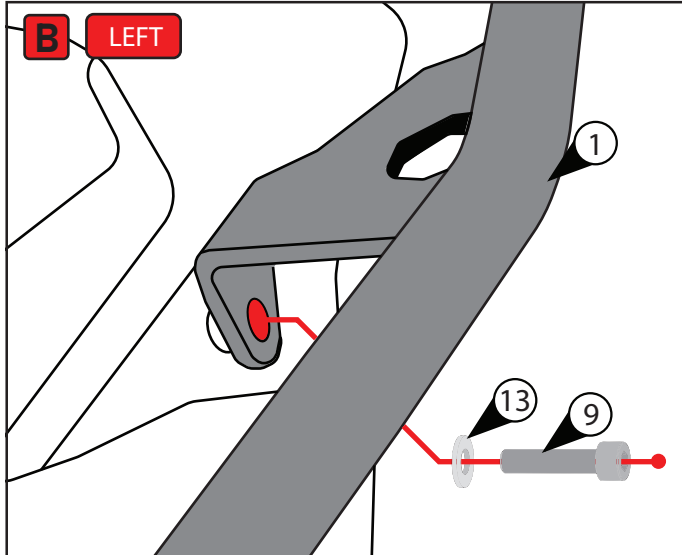

GENERAL INSTRUCTIONS

- 1. Please carefully follow the Mounting Instructions and the step-by-step procedures provided in this document.***
- 2. This manual is a DIY fitment guide for the accessory part, based on our expertise regarding the vehicle and its components.***
- 3. SRC does not guarantee compatibility with parts from other manufacturers; users should verify the original condition of all vehicle parts.***
- 4. Installed parts may affect driving behavior and vehicle stability under dynamic conditions; please be aware.***
- 5. Using proper tools and having an assistant during installation is recommended for better results.***
- 6. After installation and before the first ride, check all vehicle functions and re-inspect fasteners after 50 km and periodically.***
- 7. Our design maintains the original mounting to avoid affecting the vehicle's payload, function, or protected parts.***
- 8. Any required modifications prior to fitment will be clearly specified in the instruction sheets.***