

Part Number:

Part Description: CRASH BAR TRANSALP 750

Installation / Parts List / Bill of Material for Mounting

NO.	Description	Quantity	Torque*(N-M)	Remarks**
1	Top crash bar LH	1		
2	Top crash bar RH	1		
3	Low crash bar LH	1		
4	Low crash bar RH	1		
5	Top Bracket	1		
6	Skid plate	1		
7	Main Plate	2		
8	Pin pipe upper	2		
9	Pin pipe	1		
10	End cap	2		
11	Sliders Guards	2		
12	Socket button head screw M6x15	6		Use Liquid Thread Locker
13	Socket countersunk head screw M8x25	4		Use Liquid Thread Locker
14	Socket head cap screw M8x20	4		Use Liquid Thread Locker
15	Socket head cap screw M8x25	2		Use Liquid Thread Locker
16	Socket head cap screw M8x45	2		Use Liquid Thread Locker
17	Socket head cap screw M10x35	2		Use Liquid Thread Locker
18	Socket head cap screw M10x75	4		Use Liquid Thread Locker
-	Hex flange nut M8	4		
-	Hex flange nut M10	4		
-	Countersunk Washer M8	4		
	Washer M6	6		
	Washer M8	8		
	Washer M10	4		
SRC Design uses Metric System of Measurement and all dimensions in Millimeters				
Recommended to use the Torque specified in the table				
Denotes Usage of Liquid Thread Locker in specified Locations				

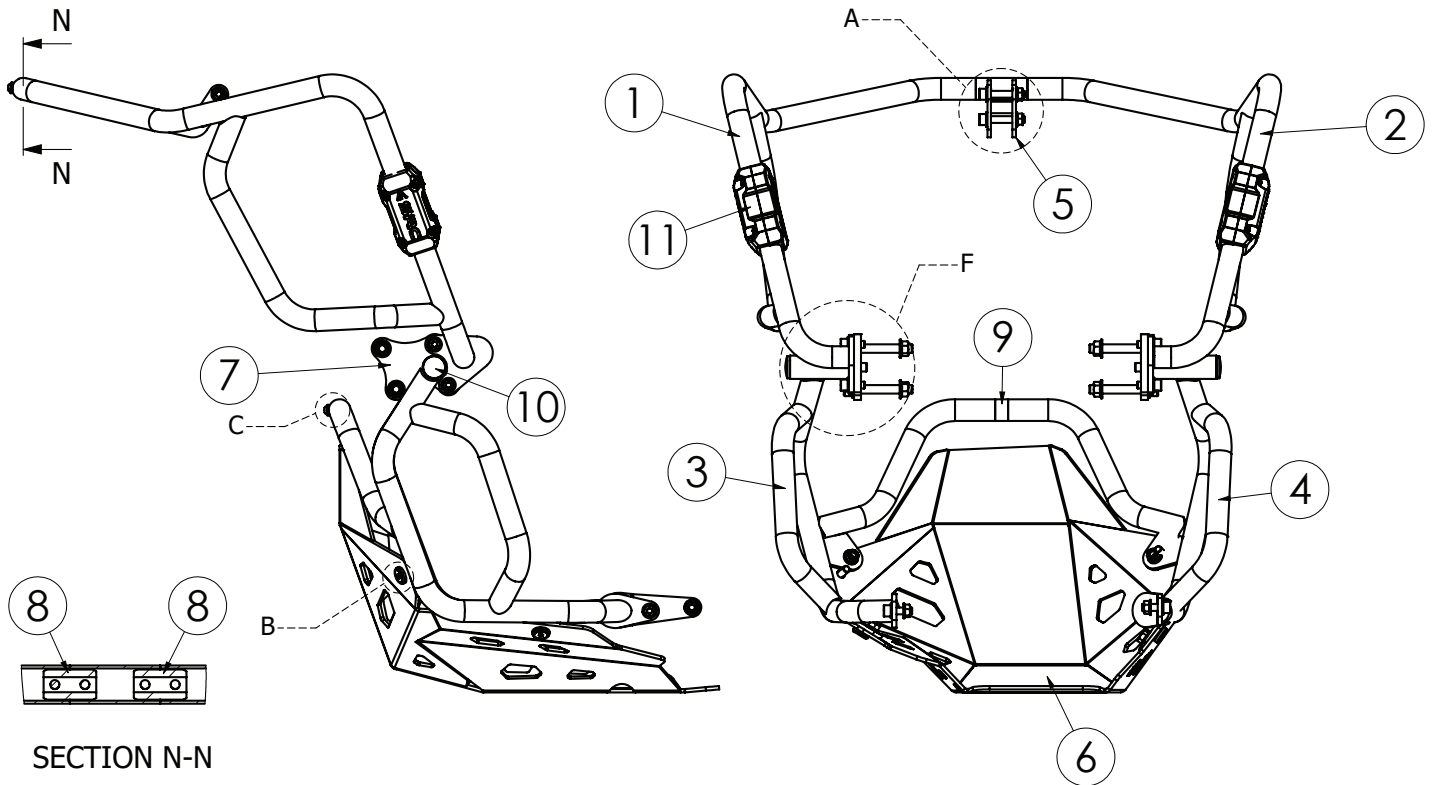

SECTION N-N  
SCALE 1 : 4

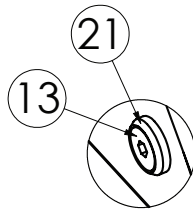
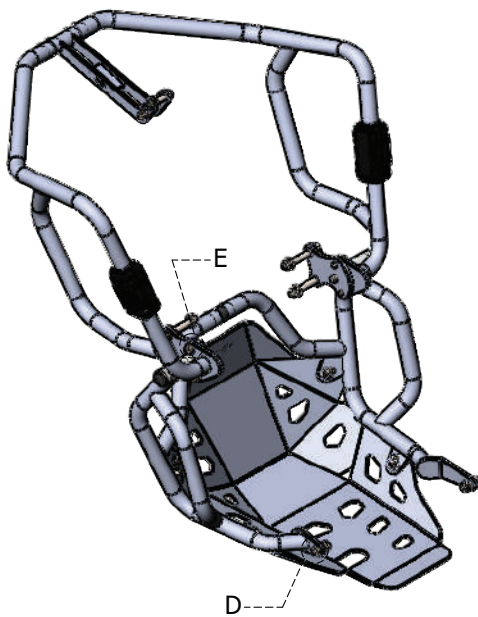

DETAIL B  
SCALE 1:2

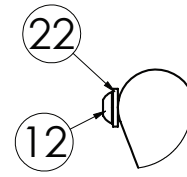

DETAIL C  
SCALE 1:2

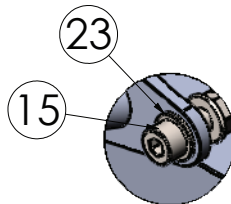

DETAIL D  
SCALE 1:2

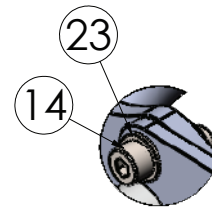

DETAIL E  
SCALE 1:2

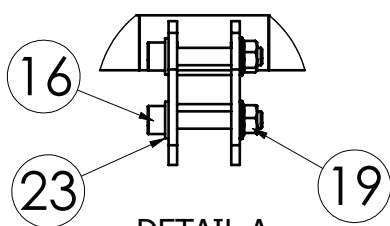

DETAIL A  
SCALE 2:7

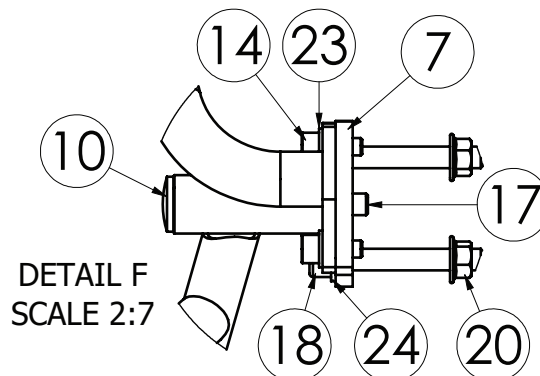

DETAIL F  
SCALE 2:7

## Torque Values to be used in Mounting Instructions



code

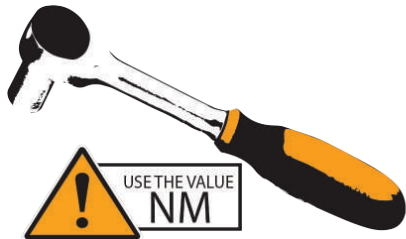

		M4		M5		M6		M8		M10		M12		M14		M16		M18	
	code	(cs)	(Fo)	(cs)	(Fo)	(cs)	(Fo)	(cs)	(Fo)	(cs)	(Fo)	(cs)	(Fo)	(cs)	(Fo)	(cs)	(Fo)	(cs)	(Fo)
<b>Inox</b>	<b>A2</b>	2.6	—	5.1	—	8.7	—	21.2	—	42	—	73	—	118	—	180	—	258	—
<b>steel</b>	<b>8.8</b>	3	3,594	5	5,886	10	8,302	23	15,242	46	24,275	79	35,401	127	48,618	198	66,955	283	83,746
<b>steel</b>	<b>10.9</b>	4	5,279	8.1	8,645	14	12,194	34	22,388	67	35,655	116	51,995	187	71,408	291	98,340	402	119,454

**Tensile load (Fo)**  
**The force in newtons (N)** which maintains pressure contact between assembled components  
**Tightening torque (Cs)** [values are in N-m]

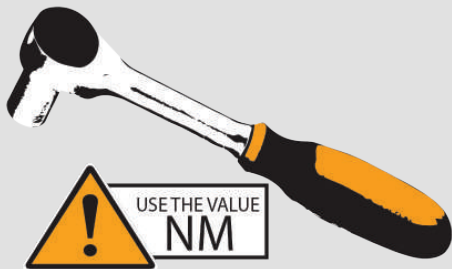

! symbol (NM), refer to the reference value given in the table above for use in the required operation And safe in operation and accuracy in inserting parts.

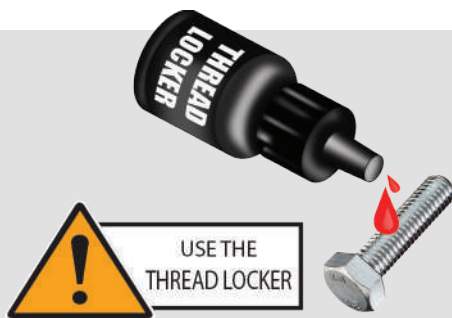

! The tool in the picture is (thread locked). When you see this mark, please insert the medicine to the point where the nut is to be inserted for the firmness and accuracy of the insertion work.

! Please check and check again to make sure that all are inserted. Every piece and don't forget any step to be safe.



RIGHT (R)

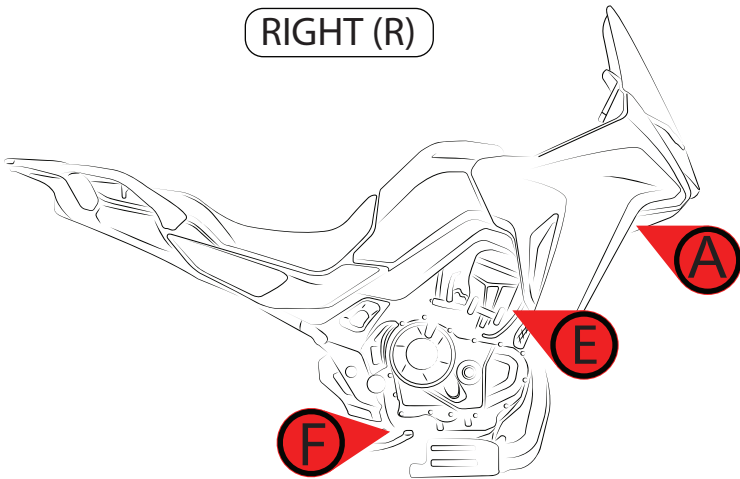

LEFT (L)

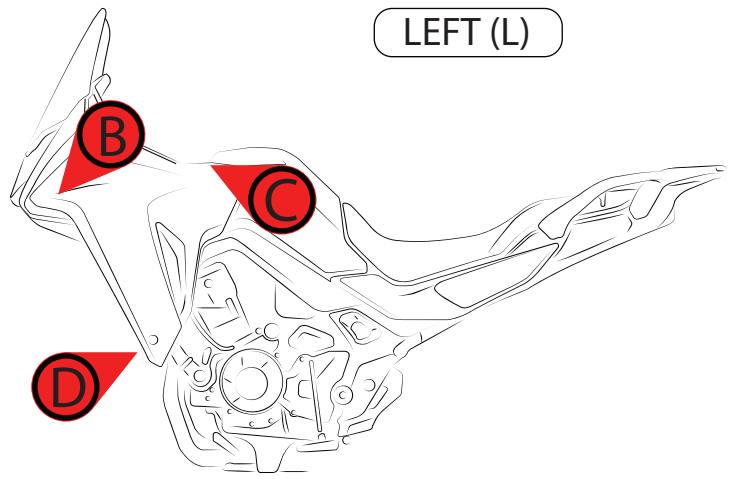

1

Remove the screws.  
, according to the illustration

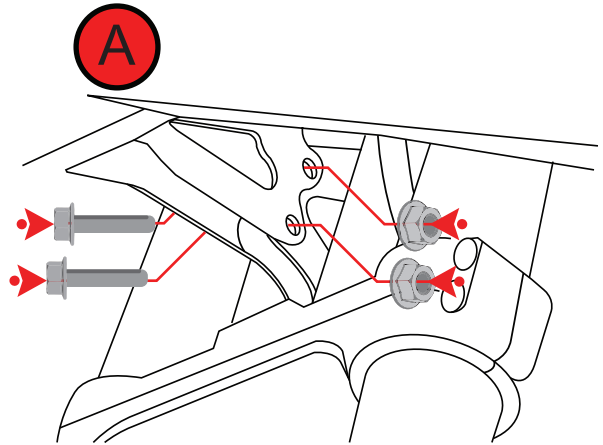

A

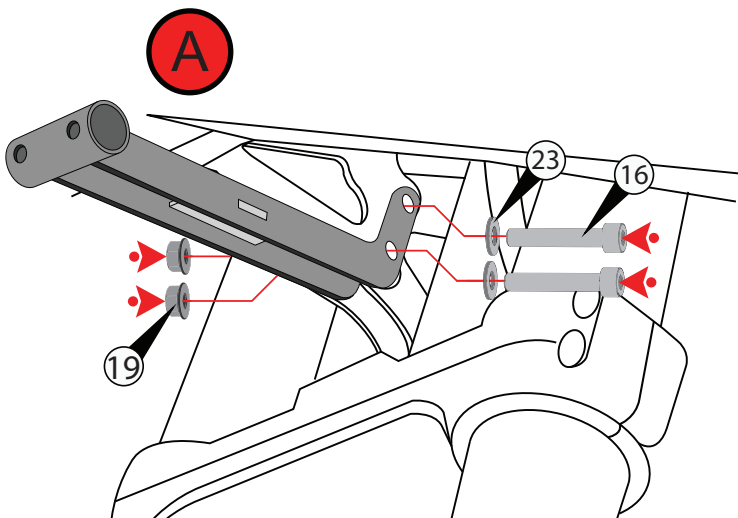

2

Insert Top Bracket  
as illustrated.

3

Remove the screws and Fairing, according to the illustration

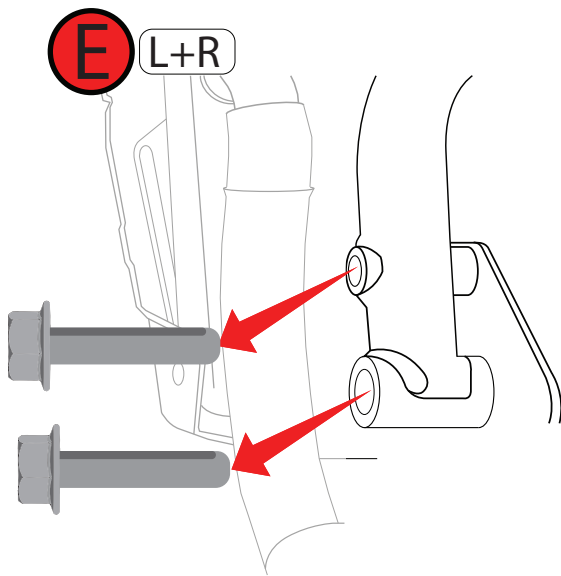
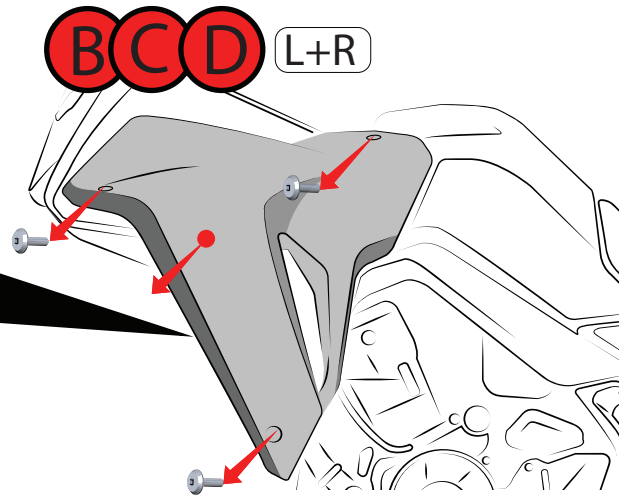
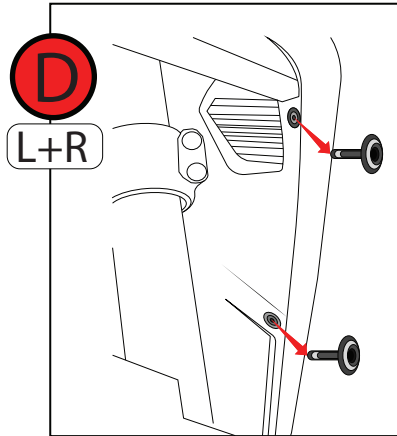

4

Remove the screws, according to the illustration

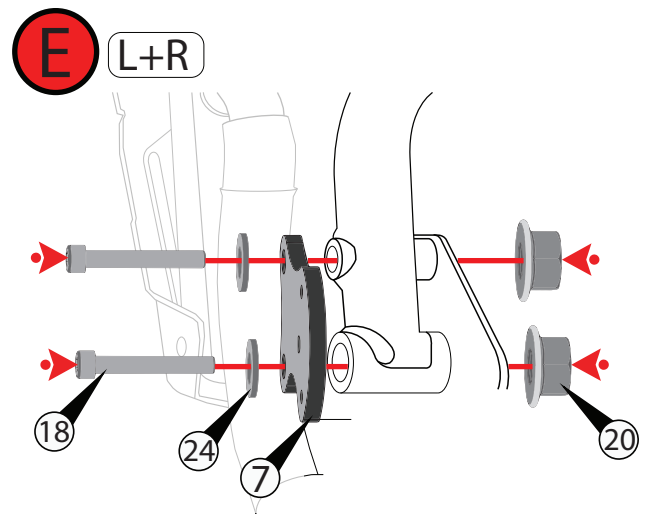

5

Prepare the parts and assemble according to the illustration.

## Installation steps

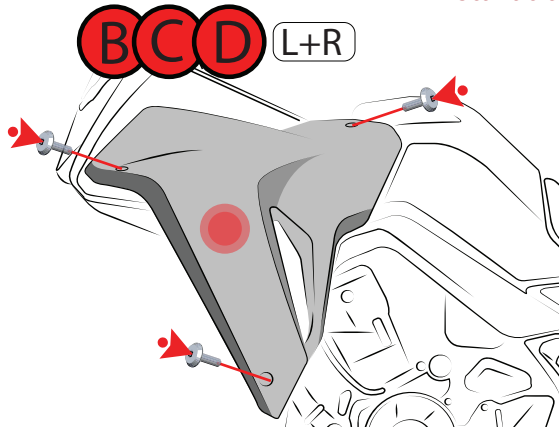

6

Insert screws and Fairing as illustrated.

7

Prepare the parts and assemble according to the illustration.

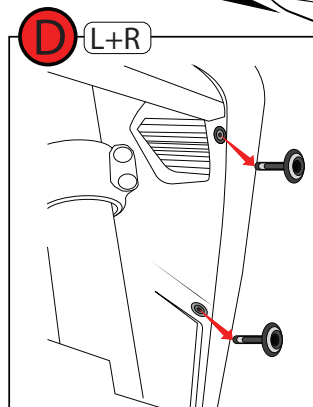
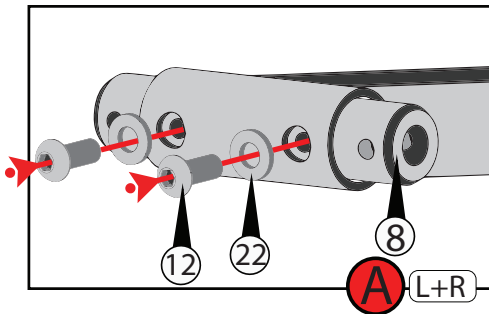

L+R

8

Prepare the parts and assemble according to the illustration.

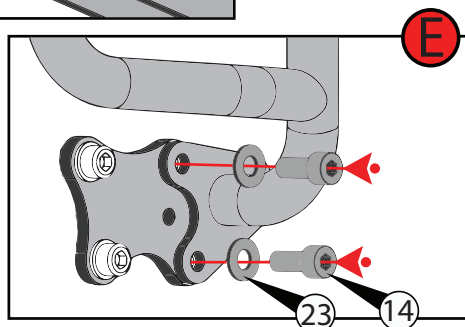
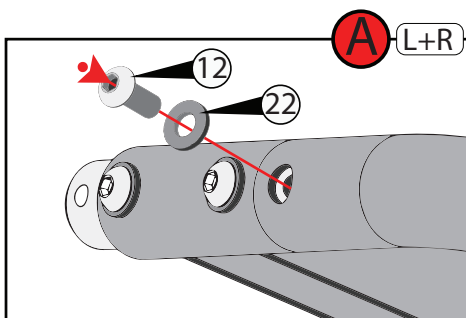

L

1

9

Prepare the parts and assemble according to the illustration.

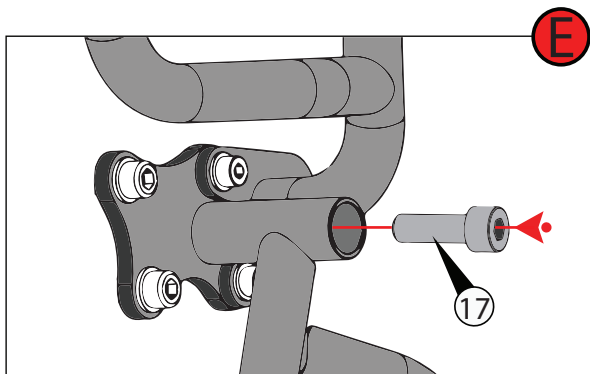
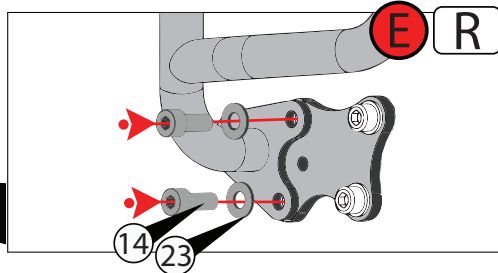
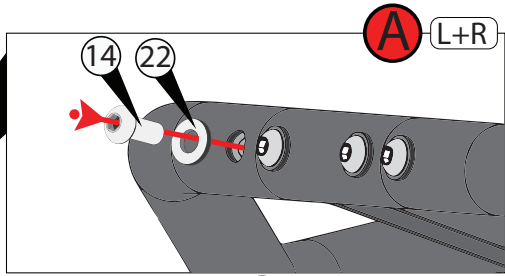
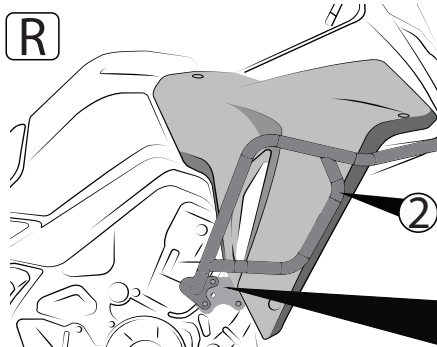

10

Prepare the parts and assemble according to the illustration.

L

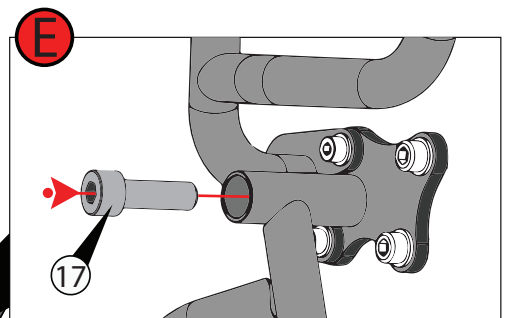
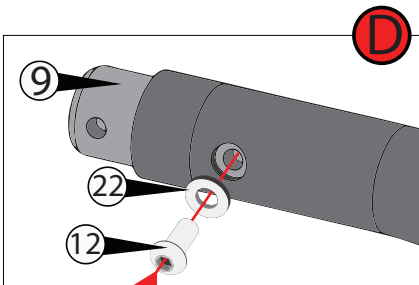
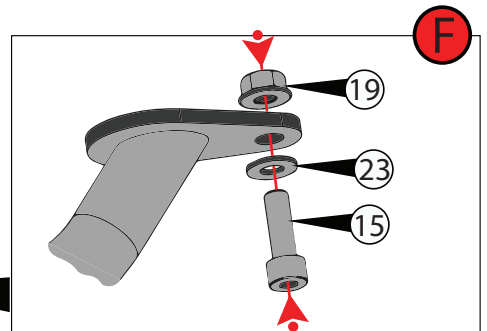

11

Prepare the parts and assemble according to the illustration.

R

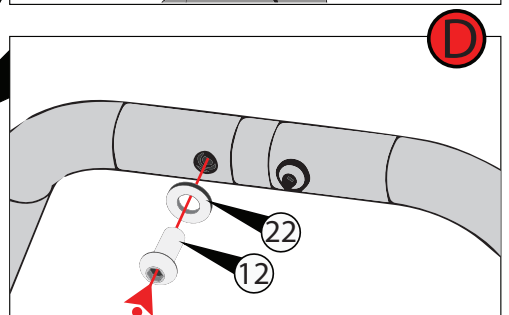
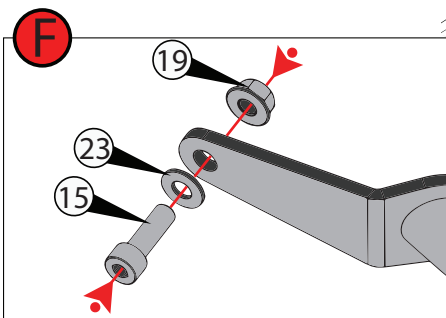

12

Insert Skid plate as illustrated.  
Insert screws as illustrated.

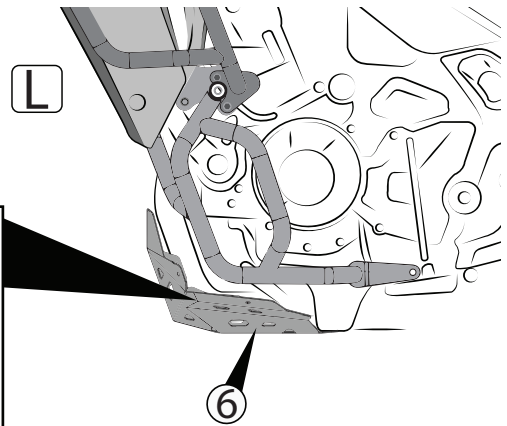
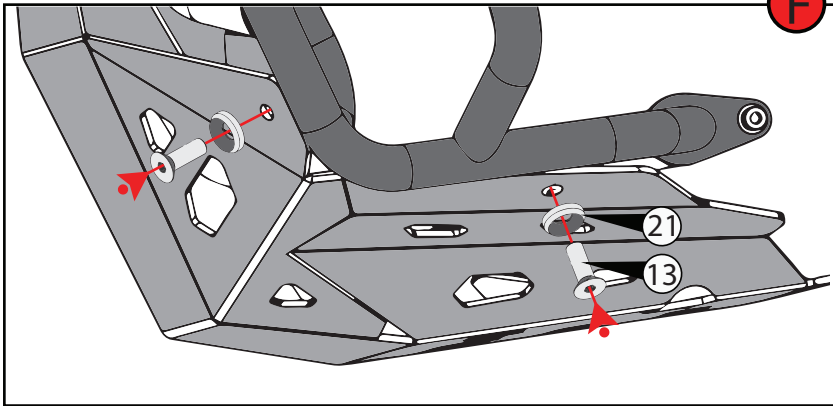

13

Insert Sliders Guards and End cap as illustrated.

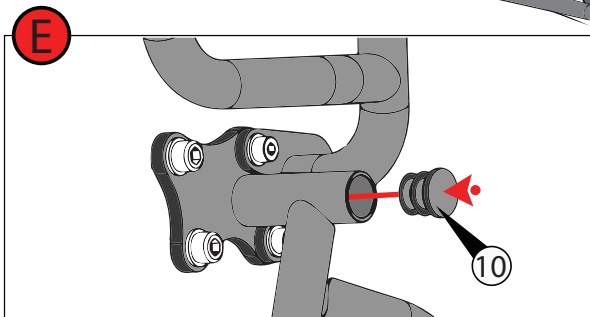

L

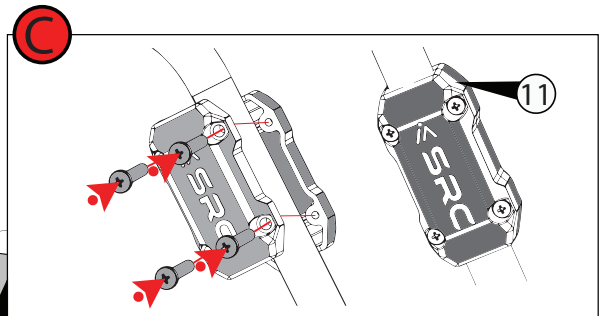

Make sure they are inserted correctly.



- (1.) We request you to pay attention to the Mounting Instructions in this document and follow the step-by-step procedures.
- (2.) This Mounting Instruction manual is a “Do It Yourself” (DIY) fitment manual of the Accessory part to the Vehicle. We have prepared this based on our experience and knowledge, related to the Vehicle, Part and its functional aspects
- (3.) SRC cannot guarantee the interchangeability of the parts to any other manufacturer’s accessory part. It is advised to the User, to inspect and ensure the original state of all other Vehicle parts.
- (4.) We request you to bear in mind, that the Installed part can change the driving behaviour and/or the stability during driving or any other dynamic conditions.
- (5.) If you have the appropriate tools and another person to assist you in the mounting, it will help.
- (6.) After Completion of the Mounting and before taking on a First ride, Ensure and Check all functions of the Vehicle. It is always advised to check loosening of the fasteners after the first 50 kilo meters of ride and at regular intervals.
- (7.) To the maximum extent possible, our design use the current Mounting/Fitment of the Original Equipment, so that Installation of these accessories will not affect the Payload or Function of the Vehicle or the Part on which it is mounted to protect it.
- (8.) If any additional modifications are to be done, prior to the fitment of the accessories, it will be explicitly specified in the instruction sheets

